



HANGCHA GROUP CO., LTD.

Factory site: 666 Xiangfu Road,
Hangzhou, Zhejiang, China (311305)

Tel: +86-571-88926735 88926755
Fax: +86-571-88926789 88132890

sales@hcforklift.com
www.hcforklift.com



Follow us on
Facebook



Follow us on
YouTube



Follow us on
WeChat



Download "Hangcha
Forklift" App



ISO45001
ISO45001:2018



ISO14001
ISO14001:2015



ISO9001
ISO9001:2015



HANGCHA trucks conform
to the European Safety
Requirements.

2025 VERSION ©COPYRIGHT 2025/07

HANGCHA GROUP CO., LTD. reserves the right to make any changes without notice concerning colors, equipment, or specifications detailed in this brochure, or to discontinue individual models. The colors of trucks, delivered may differ slightly from those in brochures.



X Series Lithium-ion Narrow Aisle Pantograph Reach Truck

with capacity of 3,000 to 4,500lbs

Making Material Handling Easier
SINCE 1956



EFFICIENT TRUCKS



The 3,000-4,500lb lithium-ion pantograph reach trucks are suitable for operations in narrow aisles and limited spaces. These trucks feature a high lift, large load capacity, pantograph, and a small turning radius. Using their advanced performance and technology, the reach trucks add to the efficiency of operations while maintaining reliability and a high level of safety. The X Series Lithium-ion Narrow Aisle Pantograph Reach Truck is the ideal tool for material handling in warehouses, supermarkets, and workshops.

Appearance

The X Series Lithium-ion Narrow Aisle Pantograph Reach Truck is designed to stack and retrieve goods efficiently in narrow warehouses and at high lift heights while still maintaining a lifting capacity of up to 4,500lbs. The exterior of this forklift is powder coated in a durable, easy to see, green finish that designates it as a lithium-ion model.

Stability

- The battery placed at the bottom of the chassis to create a low center of gravity. This allows the truck to have good stability.
- The four-pivot structure provides stability when the truck is being used to perform a high lift.



3000
~
4500
lbs Load Capacity



Reliable & Safe

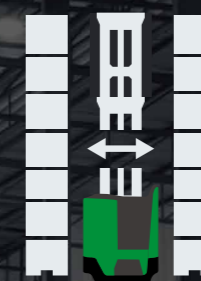

103.2"
Aisle Width

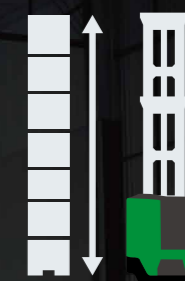

421"
Max. Lift Height

Highly Efficient

- The truck can operate in narrow aisles thanks to its small turning radius.
- Both a high-power pump motor and a silent gear pump (CONCENTRIC) are used to improve the lifting speed, lowering speed, and operating efficiency.
- With several power modes, the truck is able to adapt to different operating conditions.
- The regenerative braking system provides an increase in the truck's operating time.

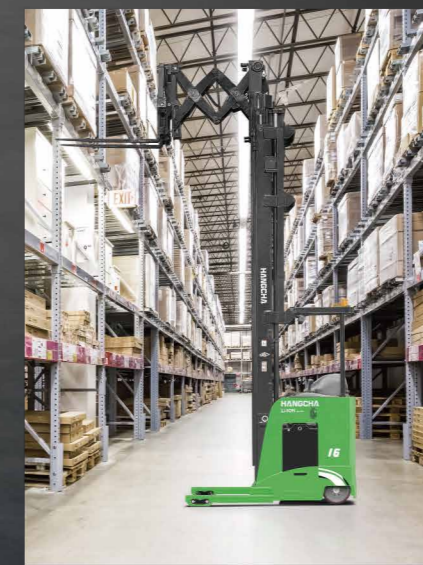

Comfort

The hanging pedal alleviates operator fatigue when driving for a long period of time by being placed in a comfortable position for the operator.



The operator is able to get on and off the truck more comfortably thanks to the low step-on height of the reach truck's operator compartment.



The handle, backrest, instruments, and switches were designed with ergonomics in mind to make operations more comfortable and flexible.



The lifting system is optimized for the operator to have an excellent line of sight through the mast.



The lateral removal of the battery provides easier maintenance and allows for the battery to be swapped out when running in continuous operating conditions.



The control handle and backrest can be adjusted according to the operator's optimal driving position.

Reliability and Safety

- The four-pivot structure, low center of gravity, and high strength of the main frame components are designed to withstand the maximum load capacity of the reach truck.
- The controller, connectors, battery plug, and cut-off switch are all parts from industry known suppliers to ensure reliability, performance, and ease of service.
- The ZF transmission, SCHABMULLER drive motor, and the efficient AC power system greatly improve the reliability and service life of the narrow aisle reach truck.
- The controller manipulates the truck's steering angle, lifting height, and traveling speed in unison to provide safer operations.



The newly designed, multi-function joystick has a unique shape and angled design helps to minimize hand movement and muscle fatigue.

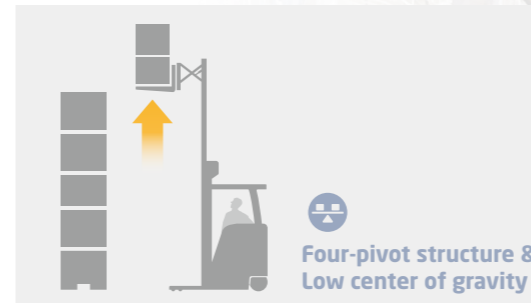

With the pedal sensing system, the truck can be driven only if the driver stands on the pedal. If the operator takes their foot off the pedal, active braking is initiated to prevent an accident.



The Full Free Lift 3 Stage Mast provides great visibility for the operator and improves operations safety.

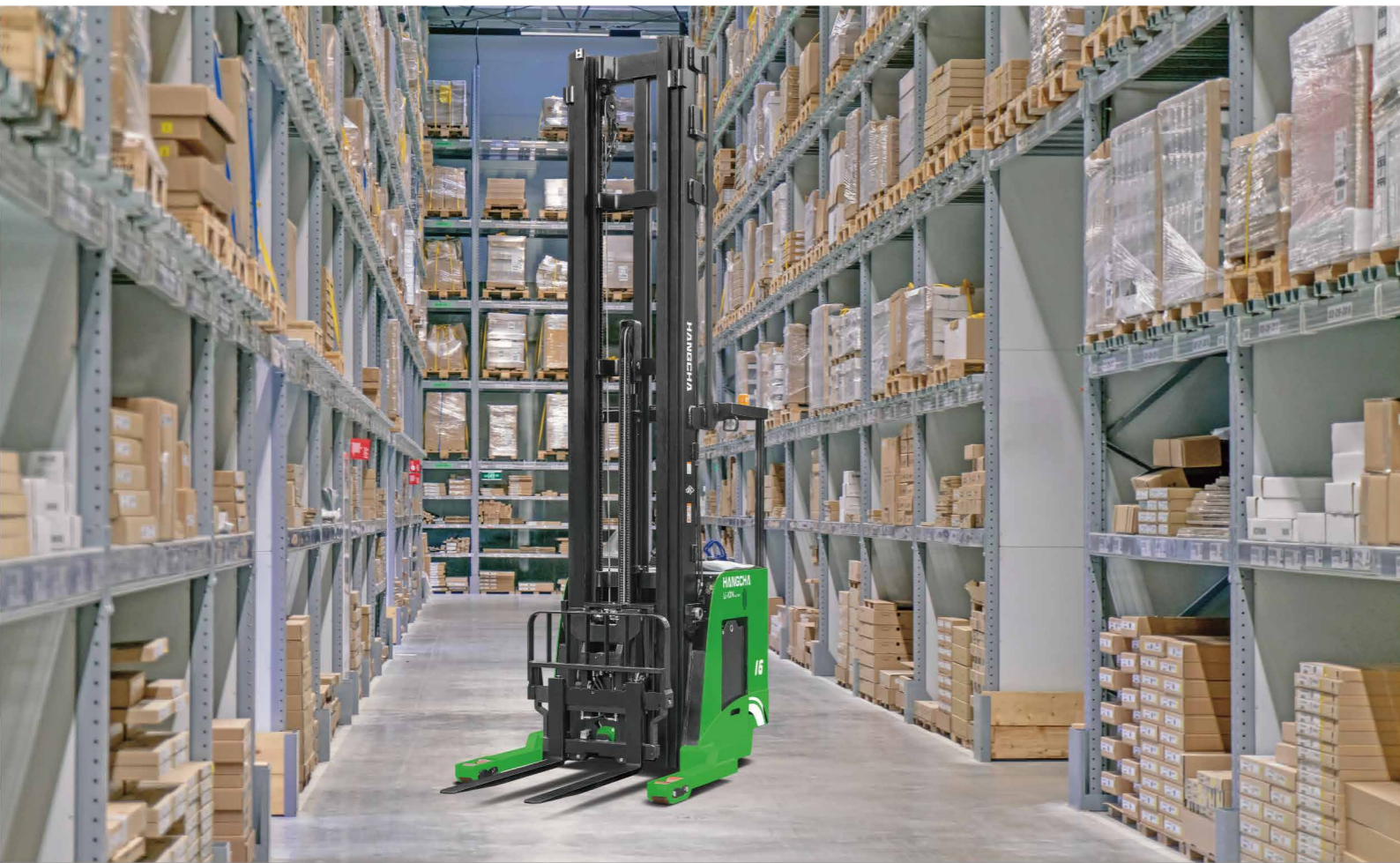

Maintenance

- The brushless AC motor is maintenance-free and significantly reduces the total cost of ownership.
- The maintenance hatch opens wide enough to enable easy repair, maintenance, and tuning of the equipment.
- The battery is maintenance-free meaning that the battery does not need to be watered or checked.
- The controller and electrical components are placed together in the chassis and are highly integrated.



The large-screen LCD display with fault self-diagnosis functions can accurately display information in harsh environments.



Advancement

- The electronic parking brake greatly improves the safety of the operator and the truck.
- The fast lifting and lowering speeds are highly efficient.
- The suspension system and hanging pedals improve operator comfort.
- The integrated mechanical, electrical, and hydraulic controls work in unison to regulate the speed of the truck when traveling and to move the forks more precisely and stably.
- The newly equipped AC control system supports longer working times by precisely managing and adjusting the performance of the truck.



High Efficiency

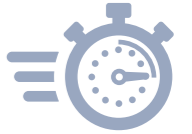

Standard Specification

- / AC Motor and Controller
- / Multi-Function Instrument Cluster
- / Electric Power Steering System
- / 198" (5.03m) Full Free-Lift Stage 3 Mast
- / Tilting Fork
- / Load Backrest
- / Overhead Guard
- / Soft Landing System
- / Safe Operating System
- / Automatically Decelerates when Cornering
- / Speed Automatic Limit when Mast High Lifting
- / Damper Pedal
- / Adjustable Backrest and Armrest
- / Battery Side Roll Out
- / Multi-Task Control Handle
- / Electro-Hydraulic Proportional Valve System
- / Polyurethane Tire
- / Headlights
- / Clipboard
- / Emergency Cut-Off Switch
- / Electric Horn
- / Static Strap
- / Electric Parking Brake
- / Strobe Light
- / Sideshifter

CATL Lithium Iron Phosphate Battery Pack

- Integrated Battery Management System (BMS) continually monitors energy management and ensures reliable operation.
- HANGCHA provides these Lithium Iron Phosphate (LiFePO₄) battery packs with up to a 6 year or 12,000 hour warranty.
- See warranty certificate for specific warranty information on the Lithium Iron Phosphate battery packs.

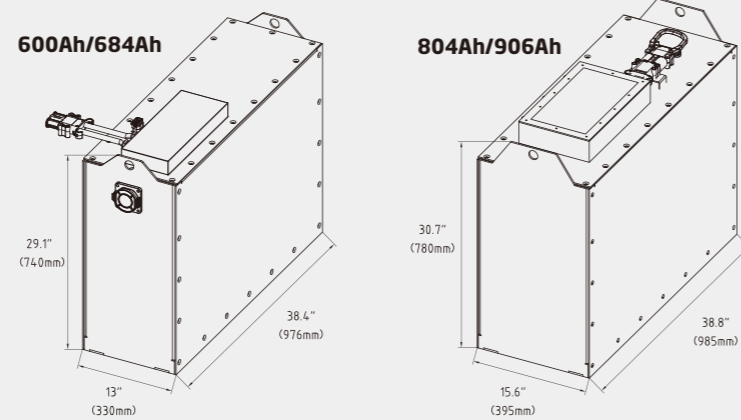

| Battery Capacity | Standard | Optional | | |
|------------------|-------------|-------------|-------------|-------------|
| [V/Ah] | 38.6V/684Ah | 38.6V/906Ah | 38.6V/600Ah | 38.6V/804Ah |
| [kW-h] | 26.40kW-h | 34.97kW-h | 23.16kW-h | 31.03kW-h |

Standard Charger (48V/200Ah)



Options

- / Charger
- / 906Ah Capacity Battery
- / Other Dimensions of Forks
- / Mast Shield
- / Widened or Heightened Load Backrest
- / Blue Light
- / Rear Working Light
- / Cabin Ceiling Light
- / Overhead Fan
- / Camera System
- / 12V Power Plug
- / Freezer
- / Fire Extinguisher